

2010 Events Schedule

- **MAAX User Group - March 22nd & 23rd - Las Vegas (*tentative dates*)**
- **NAA mediaXchange - April 11th through 14th - Orlando**
- **INMA World Congress - April 26th through 28th - New York**
- **Roundtable on Strategic Marketing - August 22nd through 25th - Vail**
- **Mini MUG - *TBD***

Mini MUG - Agenda

- **10:45 Subscriber Collections Efforts**
 - Andrew Schneider - The Washington Post
- **11:15 Campaign Automation**
 - Tony Kelly - USA Today
- **11:45 E-Edition and Community Outreach**
 - Heather Perez - Detroit Media Partnership
- **12:15 Lunch**
- **1:15 Strategies for Increasing Sales with MAAX**
 - Pete Barend - Minneapolis Star Tribune
- **1:45 Using smartREPORTER Throughout the Organization**
 - Daniel Williams - New York Times Regional Media Group
- **2:45 Break**
- **3:00 Using MAAX & EChannel - Post Points Communications**
 - Molly Urciolo - The Washington Post
- **3:30 Circulation - Starts & Saves Brainstorming - Open Forum**
 - Linda Ford - USA Today
- **4:00 smartFOCUS - Development Road Map**
 - Will Condon - smartFOCUS
- **4:30 Future Needs - Product Development - Group Forum**

Organization

smartFOCUS International

Chris Underhill
Chief Executive Officer

smartFOCUS U.K.

smartFOCUS International
Curt Bloom
President

smartFOCUS Europe

Tom Ratkovich
smartFOCUS ASTECH
President - Sales

Will Condon
VP Technical Consultancy
Pre Sales

Rebecca Toal
Business Manager

Al Frowiss
VP Intl. Services Director

Allison Ratkovich
Marketing Consultant

Anne Abernethy
Director
Client Services

Dan Towers
Director
Technical Consultancy

Tim Bailey
Education Consultant

Stewart Robotham
Support Manager
Team Leader

Gerry Gould
IT Director

Jeremy Everham
Managed Services
Team Leader

New Position
smartFOCUS
Business Development

Open Position
smartFOCUS International
Pre Sales - Denver

New Position
Project Manager

Jill Dupont-Roach
Support Analyst

Michael Christensen
Technical Architect

Renee Pawlish
Managed Services
Consultant

Mark Bell
smartFOCUS Partners
VP Business Dev

New Position
Technical Resource

Jim Visoskas
Managed Services
Consultant

Application Tools

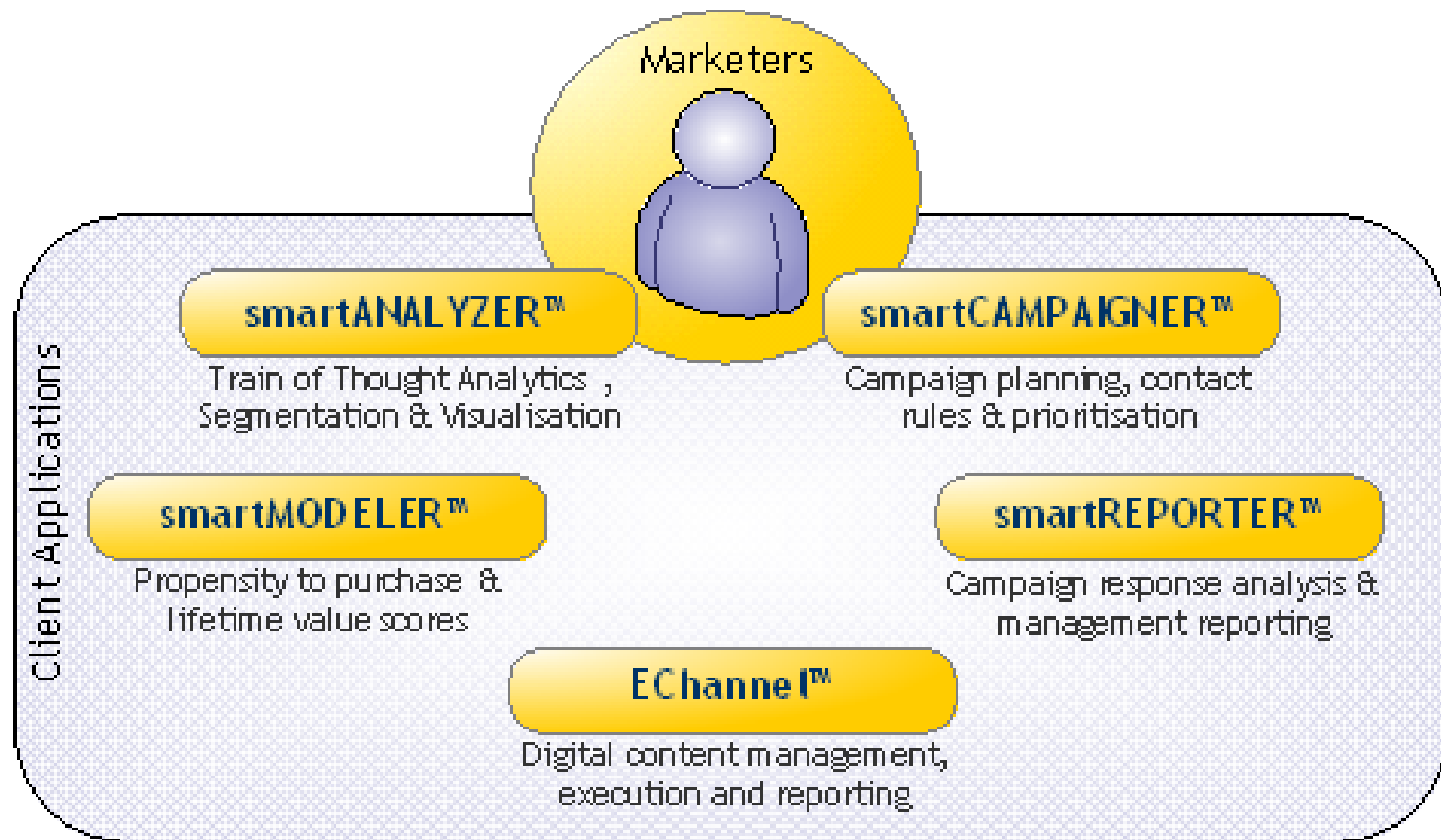

Operational Model Data, Tools & Process

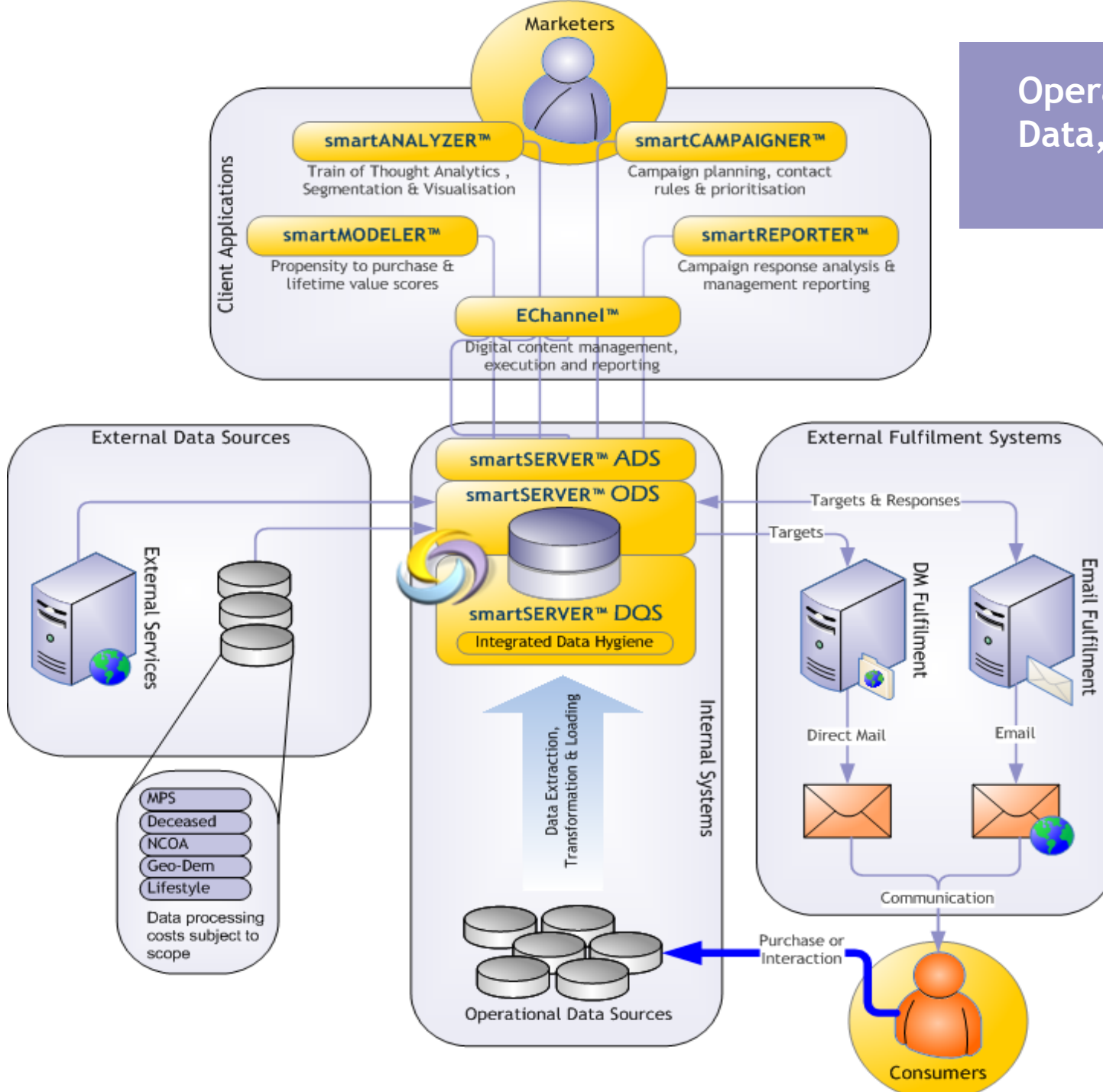

2009 Review

- **Infrastructure**

- Network Management/Monitoring Systems
- Case Support/Call Tracking System

- **Production**

- Database Updates - Automation (“Front Range”)
 - End to End Process Automation
 - Conditional & “Self-healing” Processes
 - Alerts, Notifications
- SAP/Data Services Conversion
- Quality/Resource Management
 - Database Diagnostics
 - Database Design Recommendations

Database Update Monitoring

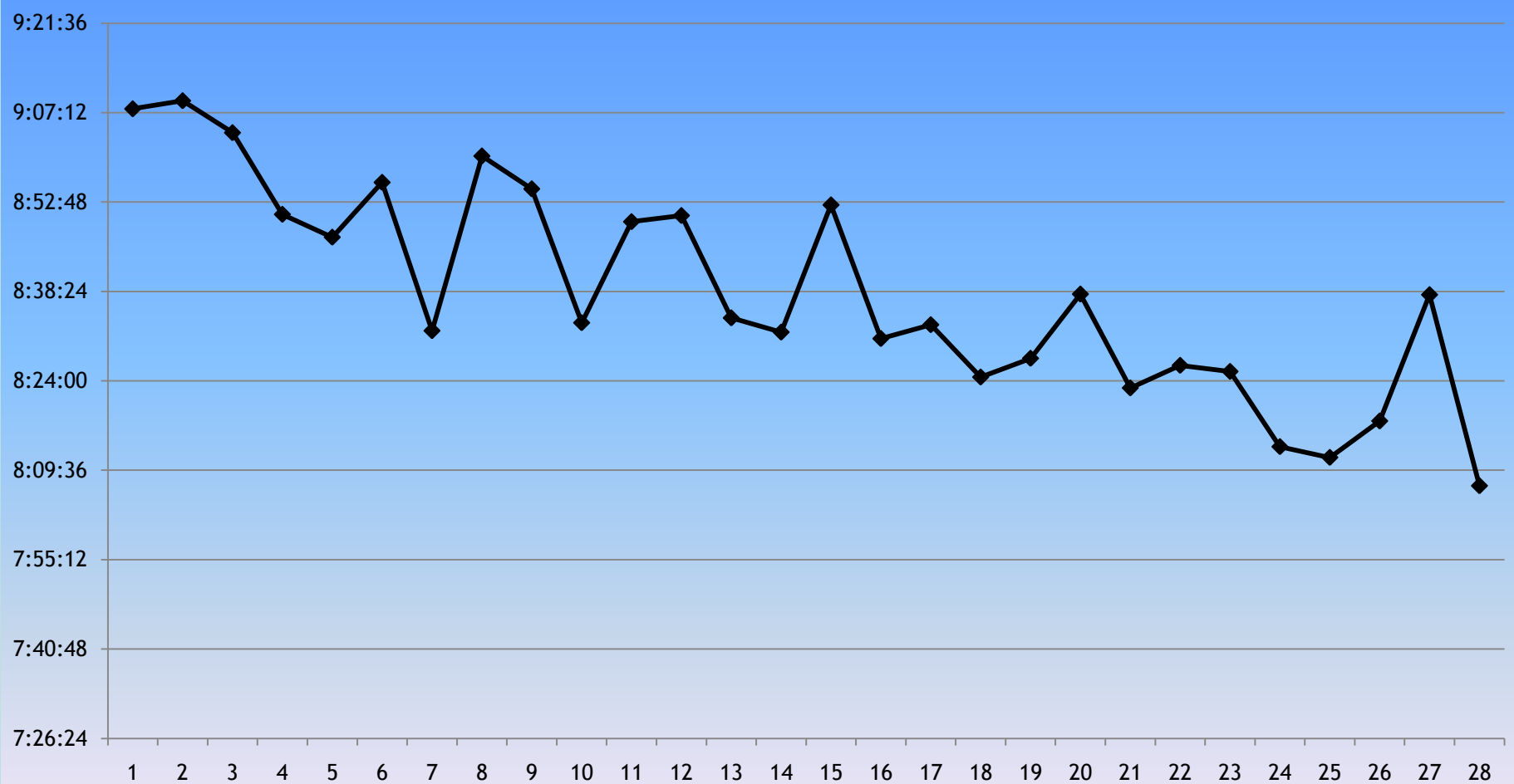

Support Cases - Monthly

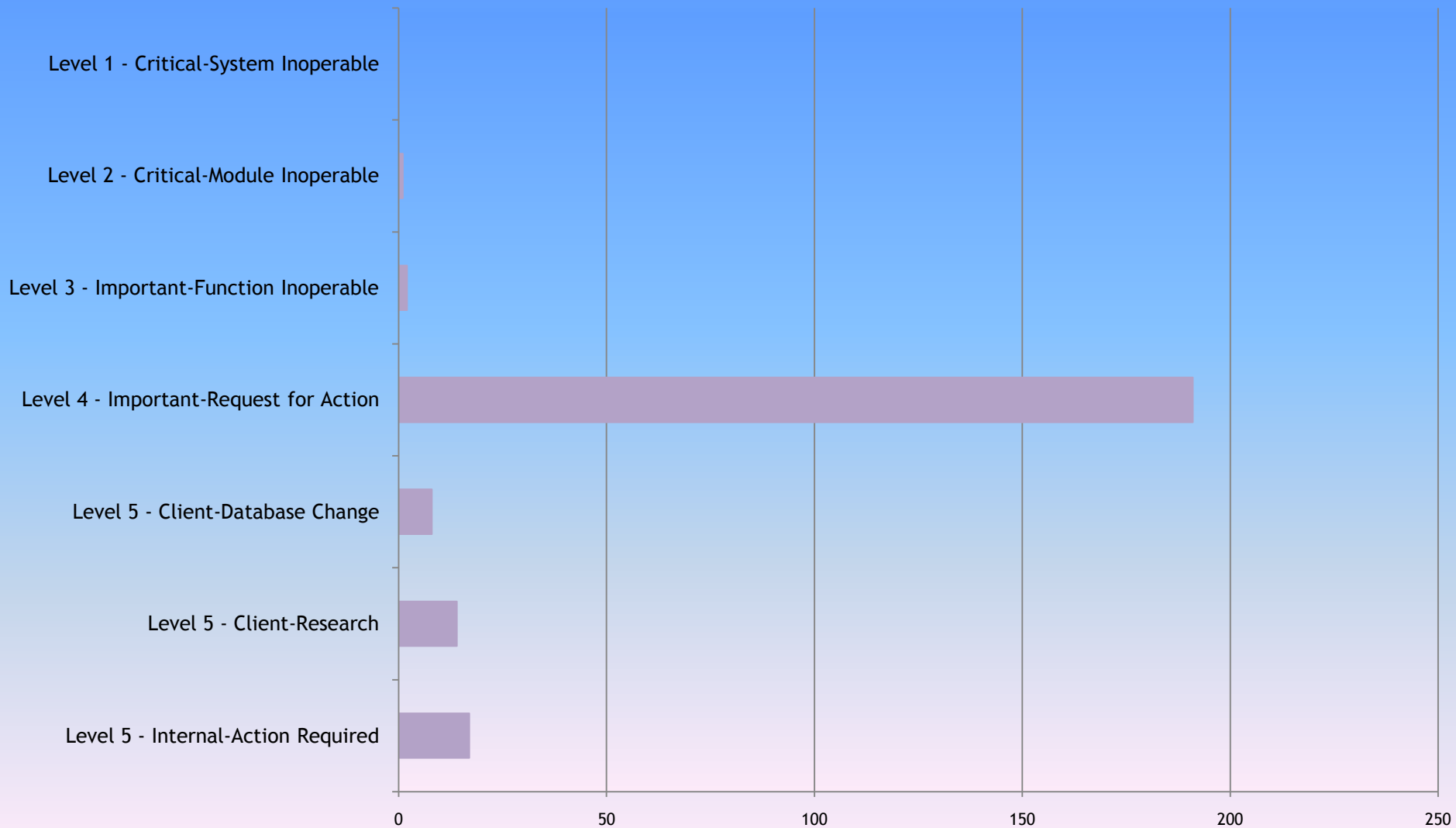

2009 Review

- **WebEx Series**

- Monthly/Bi-monthly Workshops
- Instructional/Application Focus
- Sessions recorded - “Soon” to be available from web site

- **Training Library**

- Revised Workbook
- Training Pack/Samples On Line

- **smartMARKETER EChannel “Connector”**

- Records Email Send, Receive, Opens, Clicks to SQL database
- Enables download of SQL database for analysis/integration with MAAX
- Enables upload of Campaigns/Target Lists from MAAX
- High configurability

Data Flows - EChannel Connector

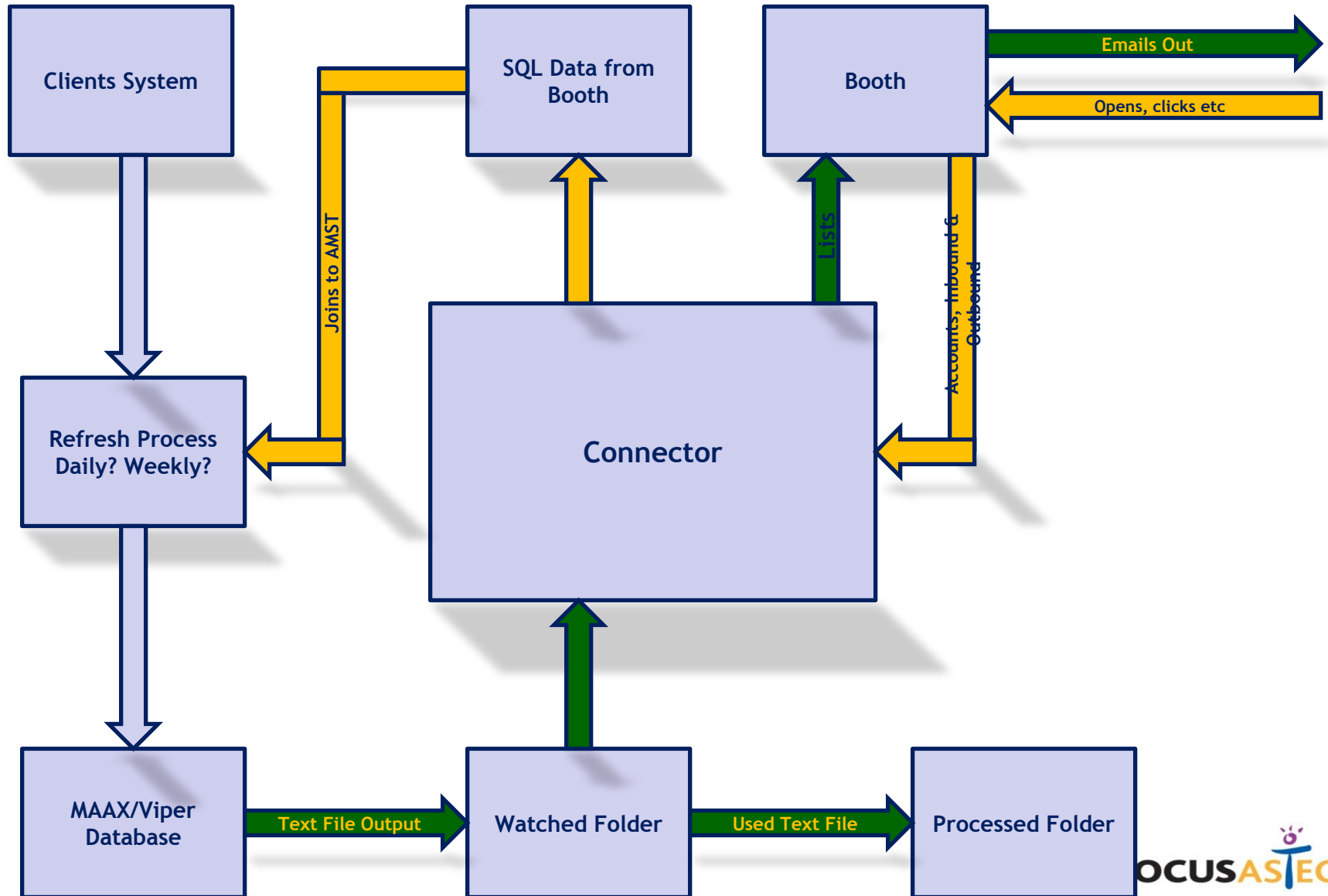

2010 Initiatives

- **Data Center**
 - Client Migration
 - Transparency
 - Citrix Web Client Interface

 - Capacity Enhancement
 - Test/Development Environment

- **Client Software Upgrade - v6.x**
 - 64 bit OS, Performance
 - New Functions/Virtual Fields
 - Backend Operation Improvements

Marketing Transformation Map: An Example

Marketing Transformation Map - Example

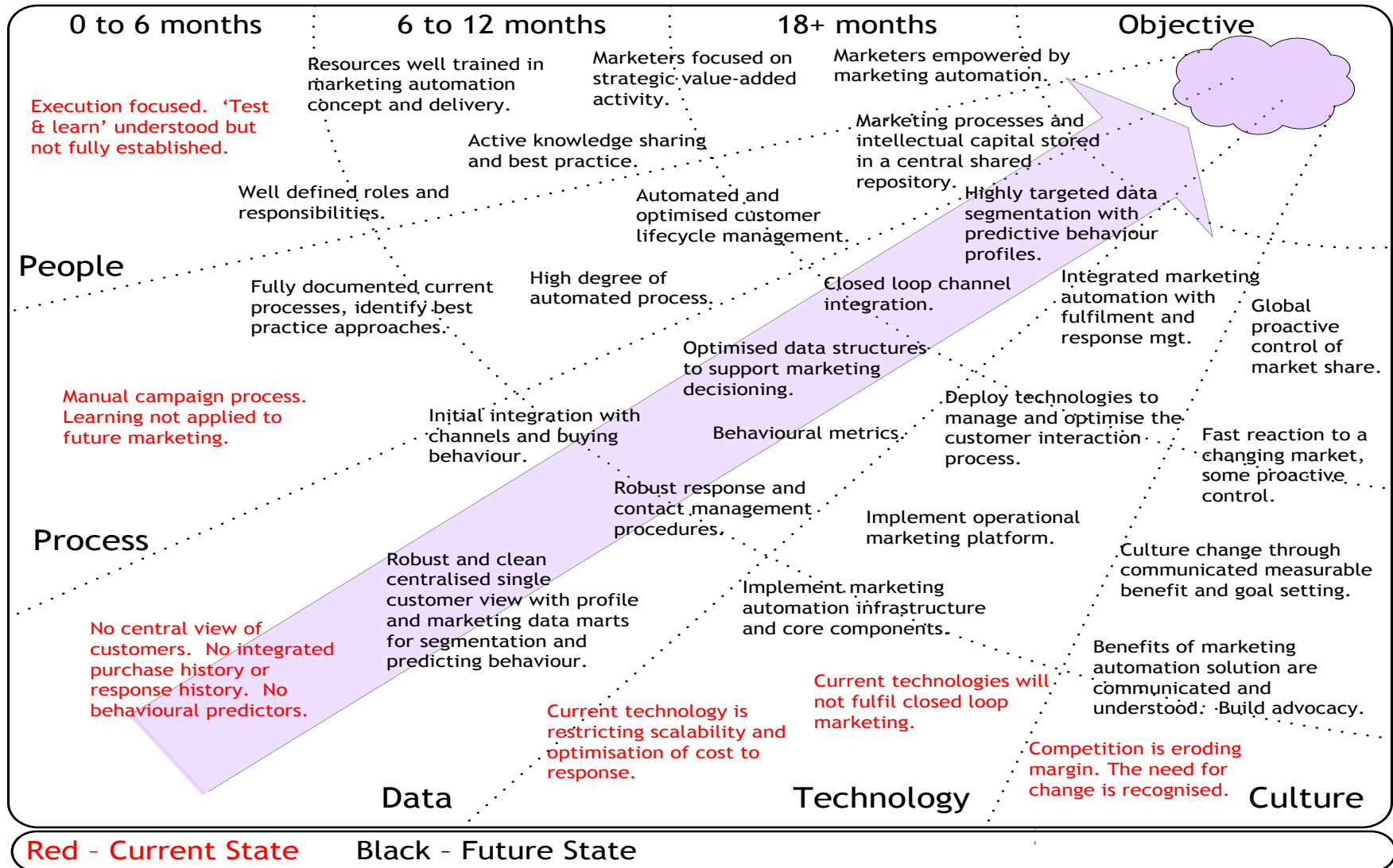

smartFOCUS ASTECH

Hosted by USA Today

November 4th & 5th 2009



mini MUG '09